



HEIDENHAIN



Product Information

ECN 1313

ECN 1325

ERN 1387

Rotary Encoders with
Plane-Surface Coupling
for Elevator Servo Drive
Control

May 2016

ECN/ERN 1300 series

Rotary encoders with integral bearings for elevator technology

- Simple installation
- Rigid shaft coupling
- Plane-surface coupling for large mounting tolerances
- Uniform dimensions for various interfaces

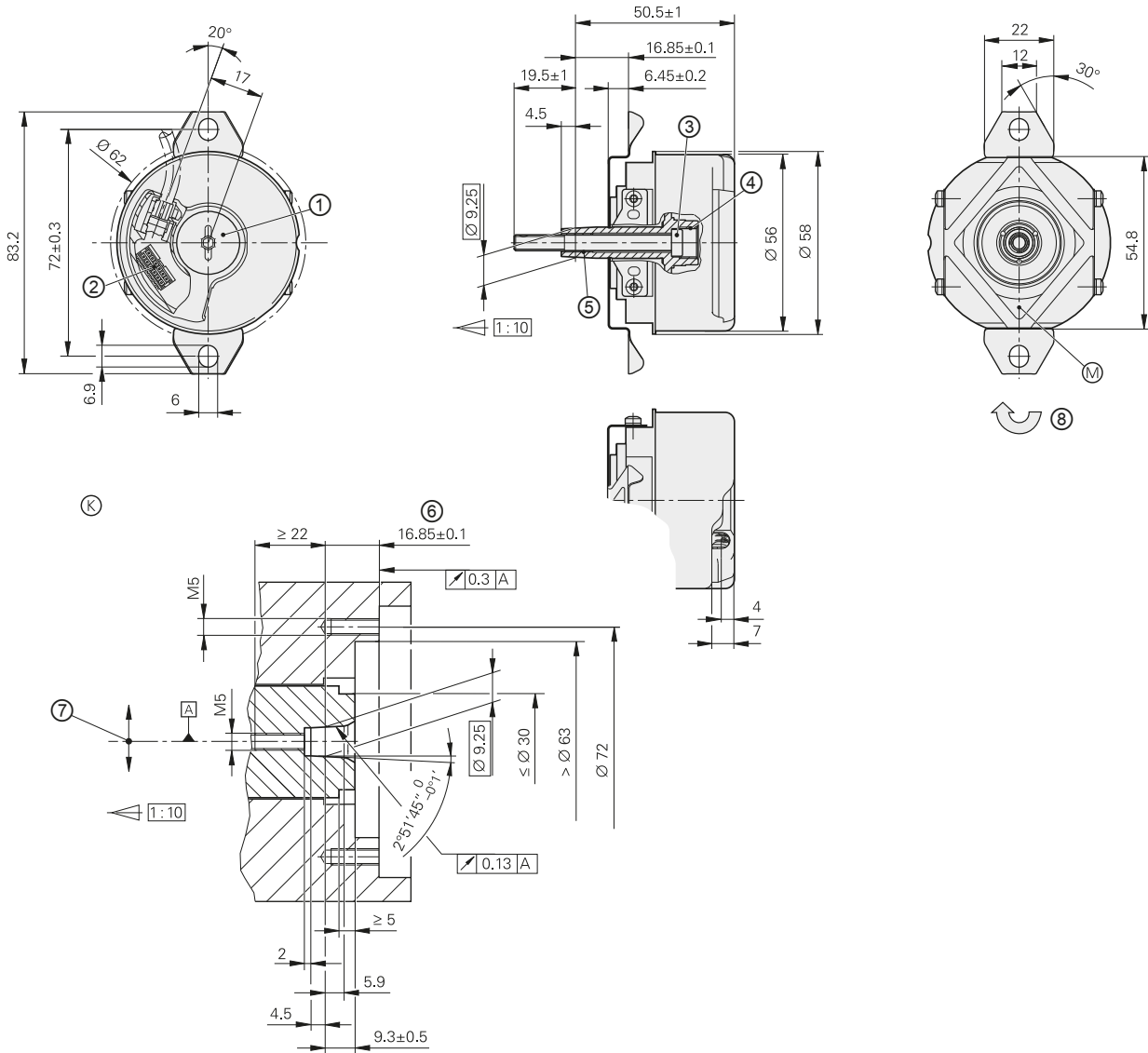

mm

 Tolerancing ISO 8015
 ISO 2768 - m H
 < 6 mm: ±0.2 mm

- ▣ = Bearing of mating shaft
- ▣ = Bearing of encoder
- ⊙ = Required mating dimensions
- ⊙ = Measuring point for operating temperature
- ① = Screw plug, widths A/F 3 and 4, tightening torque 5+0.5 Nm
- ② = 12-pin PCB connector
- ③ = Self-tightening screw M5 x 50 DIN 6912 SW4, tightening torque 5 +0.5 Nm
- ④ = M10 back-off thread
- ⑤ = M6 back-off thread
- ⑥ = Max. permissible tolerance with moving motor shaft ±1.5 mm
- ⑦ = Max. permissible static, radial offset of motor shaft in indicated direction ±0.13 mm
- ⑧ = Direction of scanning unit motion for output signals in accordance with interface description

	Absolute		Incremental
	ECN 1325	ECN 1313	ERN 1387
Interface¹⁾	EnDat 2.2		~ 1 V _{PP}
Ordering designation	EnDat22	EnDat01	–
Position values/rev	33554432 (25 bits)	8192 (13 bits)	Z1 track ³⁾
Elec. permissible speed/ Deviation ²⁾	≤ 12000 rpm (for continuous position value)	≤ 1500 rpm/±1 LSB ≤ 12000 rpm/±50 LSB	–
Calculation time t _{cal} Clock frequency	≤ 7 μs ≤ 8 MHz	≤ 9 μs ≤ 2 MHz	– –
Incremental signals ¹⁾	–	~ 1 V _{PP}	~ 1 V _{PP}
Line count*/ system accuracy	2048/±20"		2048/±20"
Reference mark	–		One
Cutoff frequency –3 dB	–	≥ 400 kHz	≥ 210 kHz
Electrical connection Via PCB connector	<i>Rotary encoder</i> : 12-pin <i>Temperature sensor⁴⁾</i> : 4-pin	12-pin	14-pin
Voltage supply	DC 3.6 V to 14 V		DC 5 V ±0.25 V
Power consumption ¹⁾ (maximum)	3.6 V: ≤ 600 mW 14 V: ≤ 700 mW		–
Current consumption	5 V: 85 mA (typical, without load)		≤ 130 mA (without load)
Stator coupling	Plane-surface coupling		
Shaft	Taper shaft Ø 9.25 mm; taper 1:10		
Mech. permissible speed n	≤ 2000 rpm		
Starting torque	≤ 0.01 Nm (at 20 °C)		
Moment of inertia of rotor	2.6 · 10 ⁻⁶ kgm ²		
Permissible axial motion of measured shaft ⁵⁾	±1.5 mm		
Radial runout of the measured shaft	0.13 mm (additional ±0.13 mm for static, radial offset)		
Vibration 55 Hz to 2000 Hz Shock 6 ms	≤ 300 m/s ² ⁶⁾ (EN 60 068-2-6) ≤ 2000 m/s ² (EN 60 068-2-27)		
Operating temperature	–40 °C to +115 °C		–40 °C to +120 °C
Protection EN 60529	IP40 when mounted		
Weight	≈ 0.25 kg		

* Please select when ordering

¹⁾ See catalog: *Interfaces of HEIDENHAIN Encoders*

²⁾ Speed-dependent deviations between the absolute value and incremental signal

³⁾ One sine and one cosine signal per revolution

⁴⁾ Evaluation optimized for KTY 84-130

⁵⁾ Compensation of mounting tolerances and thermal expansion, no dynamic motion

⁶⁾ As per standard for room temperature; the following applies for operating temperature

Up to +100 °C: ≤ 300 m/s²

Up to +115 °C or +120 °C: ≤ 150 m/s²

Electrical connection

Pin layouts

ECN 1313 pin layout

17-pin coupling or flange socket M23						12-pin PCB connector								
	Voltage supply					Incremental signals ¹⁾				Absolute position values				
	7	1	10	4	11	15	16	12	13	14	17	8	9	
	12	1b	6a	4b	3a	/	2a	5b	4a	3b	6b	1a	2b	5a
	U _P	Sensor U _P	0V	Sensor 0V	Internal shield	A+	A-	B+	B-	DATA	DATA	CLOCK	CLOCK	
	Brown/ Green	Blue	White/ Green	White	/	Green/ Black	Yellow/ Black	Blue/ Black	Red/ Black	Gray	Pink	Violet	Yellow	

Other signals		
	5	6
	/	/
	/	/
	Brown ²⁾	White ²⁾

Cable shield connected to housing; **U_P** = Power supply voltage; **T** = Temperature
Sensor: The sensor line is connected in the encoder with the corresponding power line.
 Vacant pins or wires must not be used!

- ¹⁾ Only with ordering designations EnDat 01 and EnDat 02
²⁾ Only with output cables inside the motor

ECN 1325 pin layout

8-pin coupling or flange socket M12					9-pin flange socket M23							
4-pin PCB connector		12-pin PCB connector										
	Voltage supply				Absolute position values				Other signals ¹⁾			
	8	2	5	1	3	4	7	6	/	/	/	/
	3	7	4	8	5	6	1	2	/	/	/	/
	4	/	/	/	/	/	/	/	1a	1b	/	/
	12	1b	6a	4b	3a	6b	1a	2b	5a	/	/	/
	U _P	Sensor U _P	0V	Sensor 0V	DATA	DATA	CLOCK	CLOCK	T ²⁾	T ⁻²⁾	T ^{1) 2)}	T ^{-1) 2)}
	Brown/ Green	Blue	White/ Green	White	Gray	Pink	Violet	Yellow	Brown	Green	Brown	³⁾





Cable shield connected to housing
U_P = Power supply voltage; **T** = Temperature
Sensor: The sensor line is connected in the encoder with the corresponding power line.
 Vacant pins or wires must not be used!

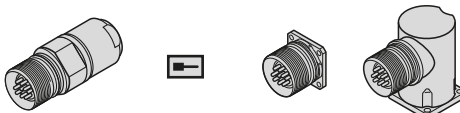
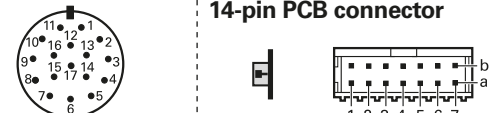

³⁾ Connections for external temperature sensor; connection in the M23 flange socket

²⁾ Only EnDat 22

³⁾ White with M23 flange socket/Green with M12 flange socket

ERN 1387 pin layout

17-pin coupling or flange socket M23						14-pin PCB connector						
												
	Voltage supply						Incremental signals					
	7	1	10	4	11	15	16	12	13	3	2	
	1b	7a	5b	3a	/	6b	2a	3b	5a	4b	4a	
	U_P	Sensor U _P	0V	Sensor 0V	Internal shield	A+	A-	B+	B-	R+	R-	
	Brown/ Green	Blue	White/ Green	White	/	Green/ Black	Yellow/ Black	Blue/ Black	Red/ Black	Red	Black	

Other signals						
	14	17	9	8	5	6
	7b	1a	2b	6a	/	/
	C+	C-	D+	D-	T+ ¹⁾	T- ¹⁾
	Gray	Pink	Yellow	Violet	Green	Brown

Cable shield connected to housing;

U_P = Power supply; **T** = Temperature

Sensor: The sensor line is connected internally with the corresponding power line. Vacant pins or wires must not be used!

¹⁾ Only with adapter cables inside the motor

HEIDENHAIN measuring equipment

PWM 20

The PWM 20 phase angle measuring unit serves together with the provided ATS adjusting and testing software for diagnosis and adjustment of HEIDENHAIN encoders.



For more information, refer to the Product Information document *PWM 20/ATS Software*.

	PWM 20
Encoder input	<ul style="list-style-type: none"> • EnDat 2.1 or EnDat 2.2 (absolute value with or without incremental signals) • DRIVE-CLiQ • Fanuc Serial Interface • Mitsubishi high speed interface • Yaskawa serial interface • Panasonic serial interface • SSI • 1 V_{PP}/TTL/11 μA_{PP} • HTL (via signal adapter)
Interface	USB 2.0
Voltage supply	AC 100 V to 240 V or DC 24 V
Dimensions	258 mm x 154 mm x 55 mm

	ATS
Languages	Choice between English and German
Functions	<ul style="list-style-type: none"> • Position display • Connection dialog • Diagnostics • Mounting wizard for EBI/ECI/EQI, LIP 200, LIC 4000 and others • Additional functions (if supported by the encoder) • Memory contents
System requirements and recommendations	PC (dual-core processor, > 2 GHz) RAM > 2 GB Windows operating systems XP, Vista, 7 (32-bit/64-bit), 8 200 MB free space on hard disk

DRIVE-CLiQ is a registered trademark of Siemens AG

Test cable for connection to PWM 20

AGK ERN 1387 , Ø 4.5 mm PUR (with shield crimping Ø 6 mm); PCB connector with strain relief 14-pin/D-sub connector (male), 15-pin incl. 3 adapter connectors, 14-pin		2 m	2 x AWG 30/7	1118892-02
AGK ECI 11xx/ECI 13xx/EQI 11xx/EQI 13xx/ExN 11xx/ExN 13xx , Ø 4.5 mm EPG (with shield crimping Ø 6 mm); PCB connector with strain relief 12-pin/D-sub connector (male) 15-pin incl. 3 adapter connectors 12-pin and 3 adapter connectors 15-pin		2 m	2 x AWG 30/7	621742-01

HEIDENHAIN

DR. JOHANNES HEIDENHAIN GmbH
 Dr.-Johannes-Heidenhain-Straße 5
 83301 Traunreut, Germany

+49 8669 31-0

+49 8669 32-5061

E-mail: info@heidenhain.de

www.heidenhain.de

This Product Information supersedes all previous editions, which thereby become invalid. The basis for ordering from HEIDENHAIN is always the Product Information valid when the contract is made.

More information

- Catalog: *Position Encoders for Servo Drives*
- Catalog: *Rotary Encoders*
- Catalog: *Interfaces of HEIDENHAIN Encoders*